

VSM19-X Translation Stage

High Performance Modular UHV Linear Sample Transporter

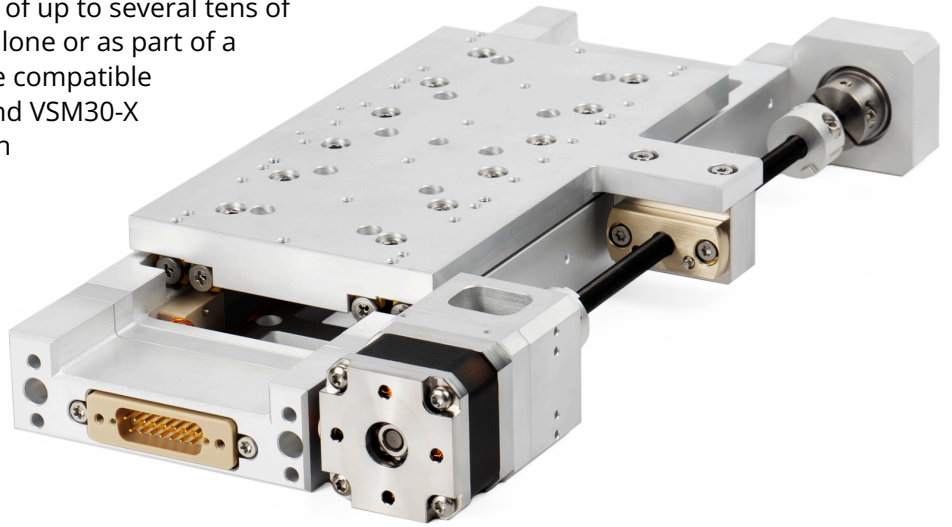

AML ultra high vacuum compatible modular linear translation stages provide translation for loads of up to several tens of kilograms. They can be used standalone or as part of a complex motion system, as they are compatible with the range of VSM17, VSM23, and VSM30-X modular stages. They have very high rigidity, which is necessary where several transporters are stacked for compound motion or where offset loads are present. Manufactured with UHV-compatible materials and precision construction techniques, the VSM19-X features AML's D35.1 UHV stepper motors for reliable performance.



FEATURES

- ! High axial load capacity with option HR.
- ! Integrated limit switches included as standard.
- ! Integrated 15-way d-sub connector included as standard.

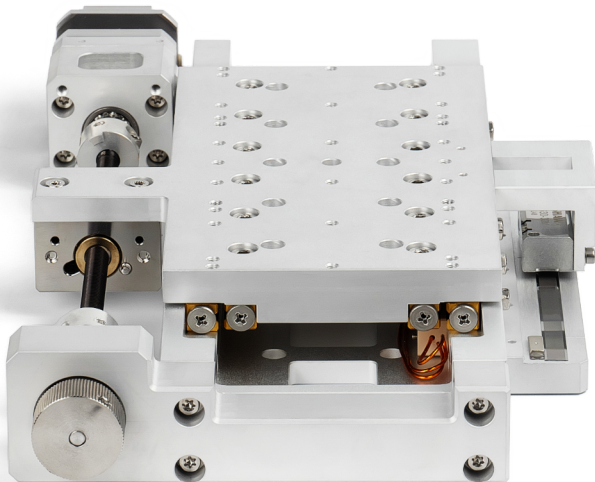

- Standard travels from 100 to 300 mm
- 5 μm resolution (1 μm for option HR)
- Better than 1 μm repeatability
- Maximum speed 15 mm/s (3 mm/s for option HR)
- Suitable for use to 1×10^{-10} mBar
- UHV-prepared aluminium construction as standard
- Stainless steel construction available (option SS)
- Bakeable to 150°C (200°C for option SS)
- Can optionally be fitted with an optical encoder - max temperature reduces to 120°C when an encoder is fitted.
- High resolution, radiation resistant and dry lubricated versions available
- Directly stackable with VSM17, VSM23, VSM30-X modular stages

SPECIFICATIONS

Specification	VSM19-X-100	VSM19-X-150	VSM19-X-200	VSM19-X-250	VSM19-X-300
Travel	100 mm	150 mm	200 mm	250 mm	300 mm
Resolution	5 μm (1 μm for option HR)				
Maximum Speed	15 mm/s (3 mm/s for option HR)				
Repeatability	Less than 1 μm				
Centred Load Capacity (Normal) (Fz)	50 kg				
Maximum Load Moment (Mr, Mp)	30 Nm				
Axial Load Capacity @ 1000 Hz 1 A Phase Current (Fa)	15 kg (50 kg with option HR)				
Backlash	Less than 1 μm				
Roll, Pitch and Yaw (Unloaded)	$\pm 60 \mu\text{rad}$	TBC	TBC	TBC	TBC
Roll, Pitch and Yaw Compliance	30 $\mu\text{rad}/\text{Nm}$	TBC	TBC	TBC	TBC
Straightness of Travel	0.003/100 mm				
Leadscrew Accuracy	0.055/100 mm				
Stepper Motor	AML D35.1				
Vacuum Environment	$< 1 \times 10^{-10}$ mBar				
Maximum Temperature	150°C (200°C for option SS) (reduces to 120°C when an optical encoder is fitted)				
MTBF (5 kg load and 30% duty cycle)	15,000 hrs				
Mass Including Motor	2 kg	2.5 kg	3.1 kg	3.4 kg	5.2 kg
Mass Including Motor (option SS)	TBC	TBC	TBC	TBC	TBC
Mass Including Motor (option HR)	2.4 kg	2.9 kg	3.5 kg	3.8 kg	5.6 kg

LOAD DIAGRAM:

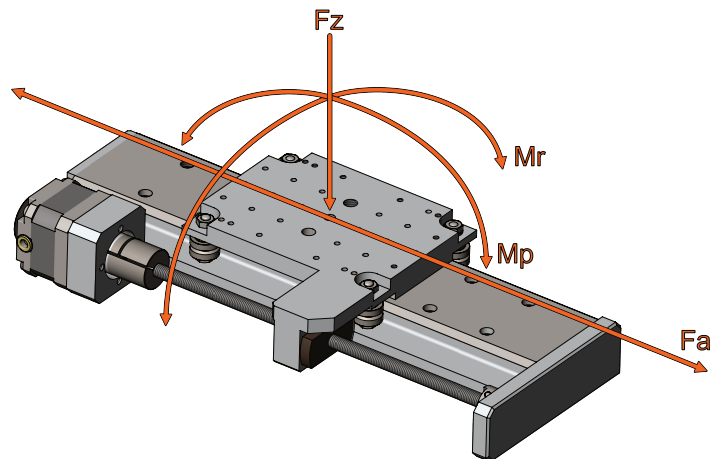

Optional Encoder Specification	ER (Incremental Encoder)	EA (Absolute Encoder)
Readhead	Renishaw TONiC™ T1630-15M	Renishaw RESOLUTE™ RL26BVE050D15V
Scale	RKLC20 20 μm pitch	RELA30 30 μm pitch
Interface Module	T10040A10A 40x interpolation factor	None
Electrical Interface	Square wave differential line driver to EIA RS422A	BiSS-C (unidirectional) 26 bit
Resolution	500 nm	50 nm

NOTES

MATERIALS: The major components of standard stages are manufactured from 6061 T6 aluminium. The material surface is processed to obtain a thin, dense aluminium oxide coating which reduces diffusion and desorption at UHV. A 304L stainless steel version can be specified using option code "SS".

BACKLASH: Backlash in the gearbox of the VSM19-X is controlled by special gearing and is negligible. Backlash between the nut and leadscrew, and axial float in the bearings is controlled by a constant force spring and is much less than the resolution. If the transporter is used for motion with a significant vertical component ($>30^\circ$), the load provided by the carriage weight is sufficient to eliminate backlash and the spring can be removed. In these cases, mount with the motor at the top. Since speeds are low, acceleration forces are negligible.

ROLL COMPLIANCE: Multiple-axis mechanisms can produce varying roll moments about the bottom transporter. The VSM19-X carriage will deflect about the roll axis at $20 \mu\text{radian per Nm}$. To achieve this performance the transporter must be fixed to an extremely rigid, flat baseplate, using all of the base fixings.

LUBRICATION: Running surfaces are dissimilar materials or dry lubricated with molybdenum disulfide. Leadscrews are lubricated with Nyetorr® 6300 UHV grease. Dry lubrication can be specified.

VERNIER STOP: These transporters may be driven to the vernier stops at the limits of their travel and stalled without damage.

STACKED MECHANISMS: For multi-axis motion, mount the stage moving the load vertically on top of the others to avoid adding their weight to its load.

IN-VACUUM CABLES

Our range of in-vacuum cables are designed for ease of connectivity between the VSM19-X and your feedthrough. We offer a standard selection which covers basic feedthrough requirements.

[Click here to view the in-vacuum cable website page.](#)

Unsure about the optimal cabling configuration for your setup? Contact the AML team so that we can learn more about your application and provide recommendations.

Custom cables can be designed to support your specific requirements. Contact the AML team for more information.

Example SMD4 Cable Configuration:

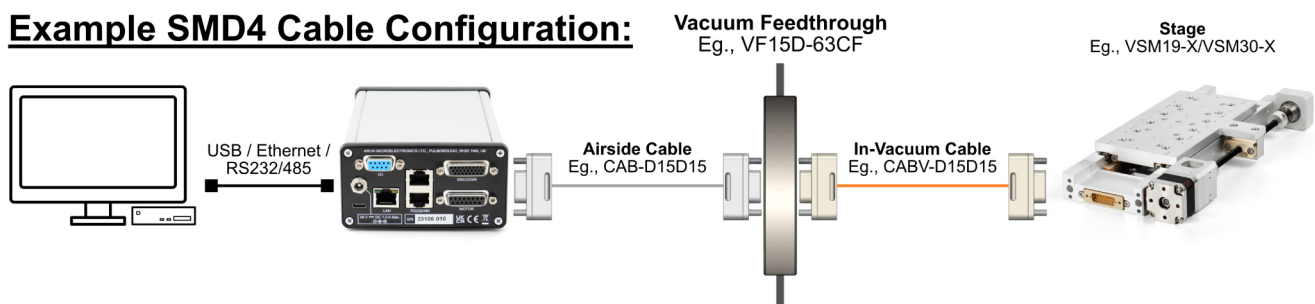

OPTIONS

- HR Adds a SG35-005 UHV inline spur gearhead. This increases the full step resolution of the stage to 1 μm . Maximum speed is reduced to 3 mm/s.

- SS Option SS is for the material of the VSM19-X to be 304L stainless steel. This increases the maximum temperature of the stage to 200°C from its standard 150°C.

- ER Adds a Renishaw TONiC™ UHV incremental encoder.
Renishaw readhead part number: T1630-15M.

- EA Adds a Renishaw RESOLUTE™ UHV absolute encoder.
Renishaw readhead part number: RL26BVE050D15V.

- R Adapts the stage so that it is radiation hardened, making it compatible with a total dose of 1E6 Gy of gamma radiation.

RELATED PRODUCTS

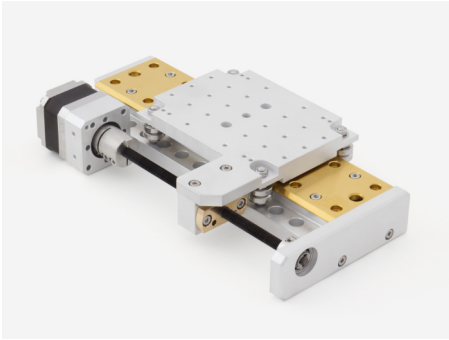

VSM23-X

Modular UHV Linear Stage.

Linear translation stage suitable for use in UHV. Travels from 100 to 450 mm. Can support centred loads up to 20 kg. 5 µm resolution allows for precise in-vacuum motion.

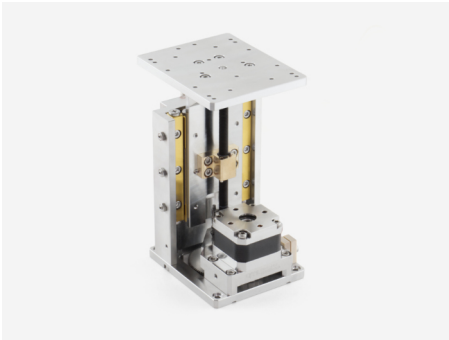

VSM17-Z

High Performance, Modular UHV Stage for Z-Axis Translation.

Linear vertical translation stage suitable for use in UHV. Can support loads of up to several kilograms and travel from 50 mm. Designed specifically for Z-axis translation with its high load capacity.

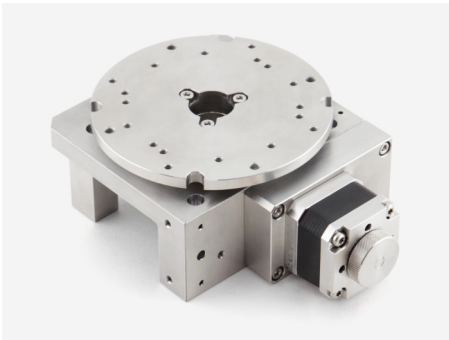

VSM17-R

High Performance, Modular UHV Rotation Stage.

Rotation stage suitable for use in UHV. Can support loads of up to 100 kilograms. Resolutions from 0.1° to 0.005° with 360° of continuous rotation.

ORDERING INFORMATION

Order Code	
VSM19-X-xxx	Linear stage (xxx=travel in mm)
VSM19-X-xxx-SS	Linear stage, stainless steel
VSM19-X-xxx-HR	Linear stage, 1 µm resolution
VSM19-X-xxx-ER	Linear stage with encoder (incremental)
VSM19-X-xxx-EA	Linear stage with encoder (absolute)
VSM19-X-xxx-R	Linear stage, radiation resistant

Example Order Code	
VSM19-X-100-HR-EA	Linear stage, 100 mm travel, 1 µm resolution, absolute encoder.



Arun Microelectronics Ltd.
 Unit 2, Bury Mill Farm
 Bury Gate
 PULBOROUGH
 RH20 1NN
 United Kingdom

Tel: +44 (0)1903 884141
 Email: sales@arunmicro.com

AML pursues a policy of continuous improvement and reserves the right to make detail changes to specifications without consultation. E and OE.