

VSM17-R-72K Rotation Stage

Modular UHV Rotation Sample Transporter

AML ultra high vacuum compatible rotation stages are manufactured with UHV compatible material and construction methods in an ISO 7 cleanroom and utilise AML D35.1 UHV stepper motors.

The VSM17-R-72K stage feature a precision cross-roller ring bearing system, providing high rotational accuracy capable of bearing loads in every direction. It has a 18 mm clear aperture, worm and wheel gearing and can optionally be fitted with an optical UHV compatible rotary encoder.

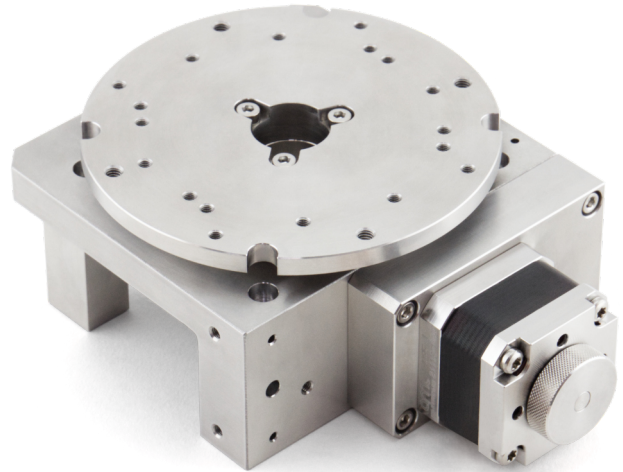

FEATURES

- 360° rotation range
- 0.005° resolution
- Better than resolution unidirectional repeatability
- Maximum loaded speed of up to 4 rpm
- Maximum torque of up to 8 Nm
- Suitable for use to 1×10^{-10} mBar
- Bakeable to 200 °C
- 100 kg centre load capacity
- Features AML D35.1 stepper motor
- Can optionally be fitted with a limit switch or an optical encoder
- Radiation resistant versions available
- Directly stackable for XYZ orientations
- Compatible with VSM17 modular stages
- May be customised for specific requirements
- Lubricated with NyeTorr® 6300 grease

SPECIFICATIONS

Specification	VSM17-R-72K
Rotation Range	360°
Resolution in Full Steps	0.005°
Steps per Revolution	72,000
Maximum Loaded Speed	4 rpm
Maximum Loaded Motor Step Frequency	5 kHz
Gear Type	Worm and Wheel
Centred Load Capacity (Normal)	100 kg
Maximum Torque	8 Nm
Detent Torque	N/A
Backlash (Unloaded)	0.2°
Concentricity	±8 µm
Vacuum	1 x 10 ⁻¹⁰ mBar
Maximum Temperature	200°C (reduces to 120°C when an optical encoder is fitted)
Aperture Diameter	18 mm
Motor	D35.1
Mass Including Motor	1.66 kg

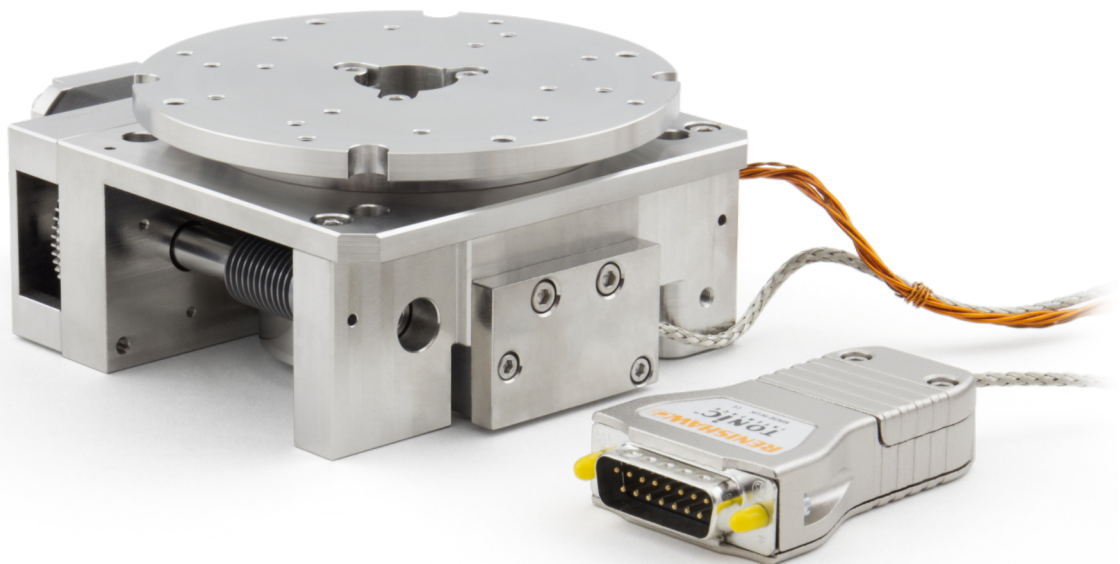

VSM17-R-72K-E:

Modular UHV rotation stage with optional optical encoder.

DIMENSIONS

VSM17-R-72K

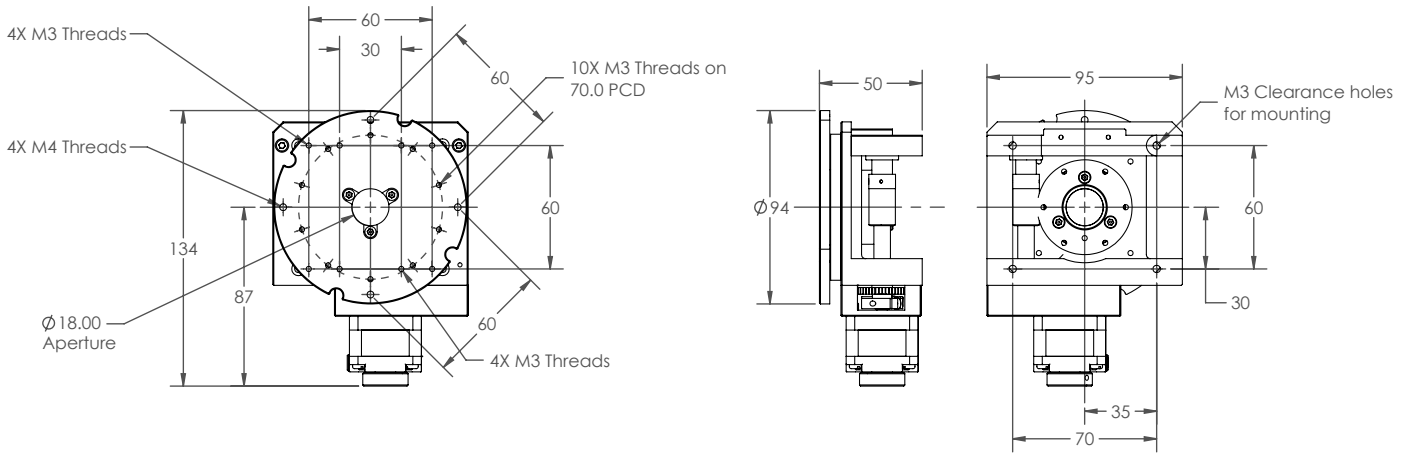

RELATED PRODUCTS

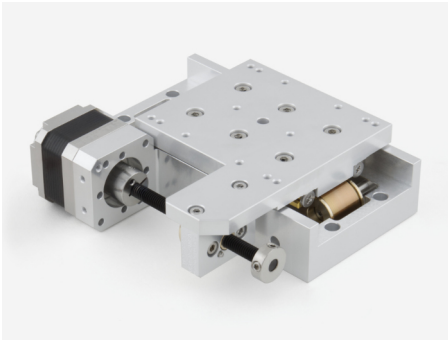

VSM17-X

High Performance, Modular UHV Compatible Stage.

Linear translation stage suitable for use in UHV. Can support loads of up to several kilograms and travel from 50 to 200 mm. 5 μ m resolution allows for precise in-vacuum motion.

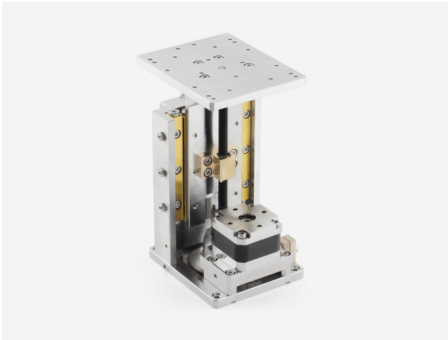

VSM17-Z

High Performance, Modular UHV Stage for Z-Axis Translation.

Linear vertical translation stage suitable for use in UHV. Can support loads of up to several kilograms and travel from 50 mm. Designed specifically for Z-axis translation with its high load capacity.

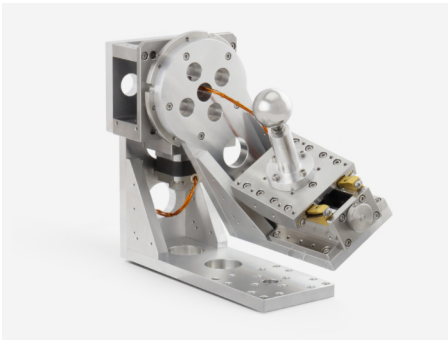

VSM17-G

High Performance, Modular UHV Goniometer Stage.

Goniometer stage suitable for use in UHV. It is possible to build a Euler goniometer with a common centre of rotation.

ORDERING INFORMATION

Order Code	
VSM17-R-72K	Rotation stage
VSM17-R-72K-LS	Rotation stage with limit switch
VSM17-R-72K-ER	Rotation stage with encoder (incremental)
VSM17-R-72K-EA	Rotation stage with encoder (absolute)
VSM17-R-72K-R	Rotation stage, radiation resistant



Arun Microelectronics Ltd.
Unit 2, Bury Mill Farm
Bury Gate
PULBOROUGH
RH20 1NN
United Kingdom

Tel: +44 (0)1903 884141
Email: sales@arunmicro.com

AML pursues a policy of continuous improvement and reserves the right to make detail changes to specifications without consultation. E and OE.