

Vacuum Stage Mounting Brackets

Vacuum Stage Accessories

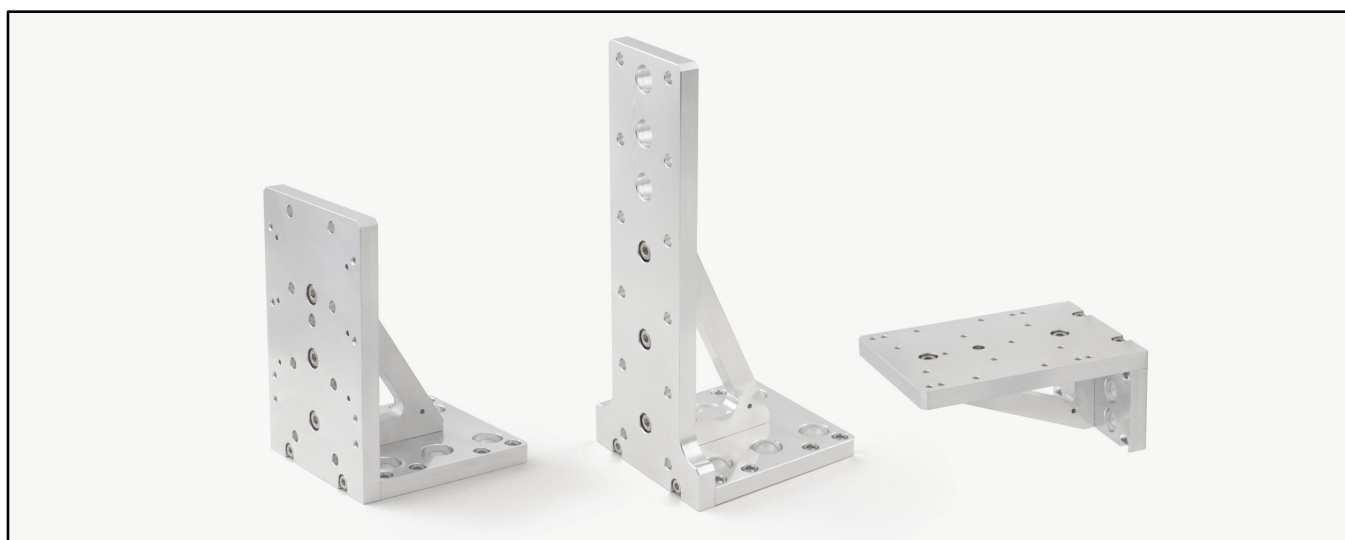

AML UHV compatible mounting brackets for use with VSM stages. Used to reorient stages or design multi-axis mechanism with standard products. AML mounting brackets are constructed with lightweight uhv-prepared aluminium to reduce mass whilst maintaining stability.

- Designed for AML VSM stages
- Suitable for use to 1×10^{-10} mBar
- Bakeable to 150°C (200°C for option SS)
- Create multi-axis systems with standard products
- Lightweight UHV-prepared construction
- Stainless-steel construction available (option SS)
- Adapt linear stages for vertical translation
- Custom mounting brackets available

SPECIFICATIONS

Specification	VSAB01	VSAB02	VSAT01
Mass	0.27 kg (0.81 kg for option SS)	0.29 kg (0.87 kg for option SS)	0.22 kg (0.66 kg for option SS)
Maximum Temperature	150°C (200°C for option SS)		
Perpendicularity (per 100 mm)	0.02°		
Vacuum	1×10^{-10} mBar		

NOTES

MATERIALS: Mounting brackets are manufactured from 6061 T6 aluminium. The material surface is processed to obtain a thin, dense aluminium oxide coating which reduces diffusion and desorption at UHV. A 304L stainless steel version can be specified using option code "SS".

DIMENSIONS

VSAB01

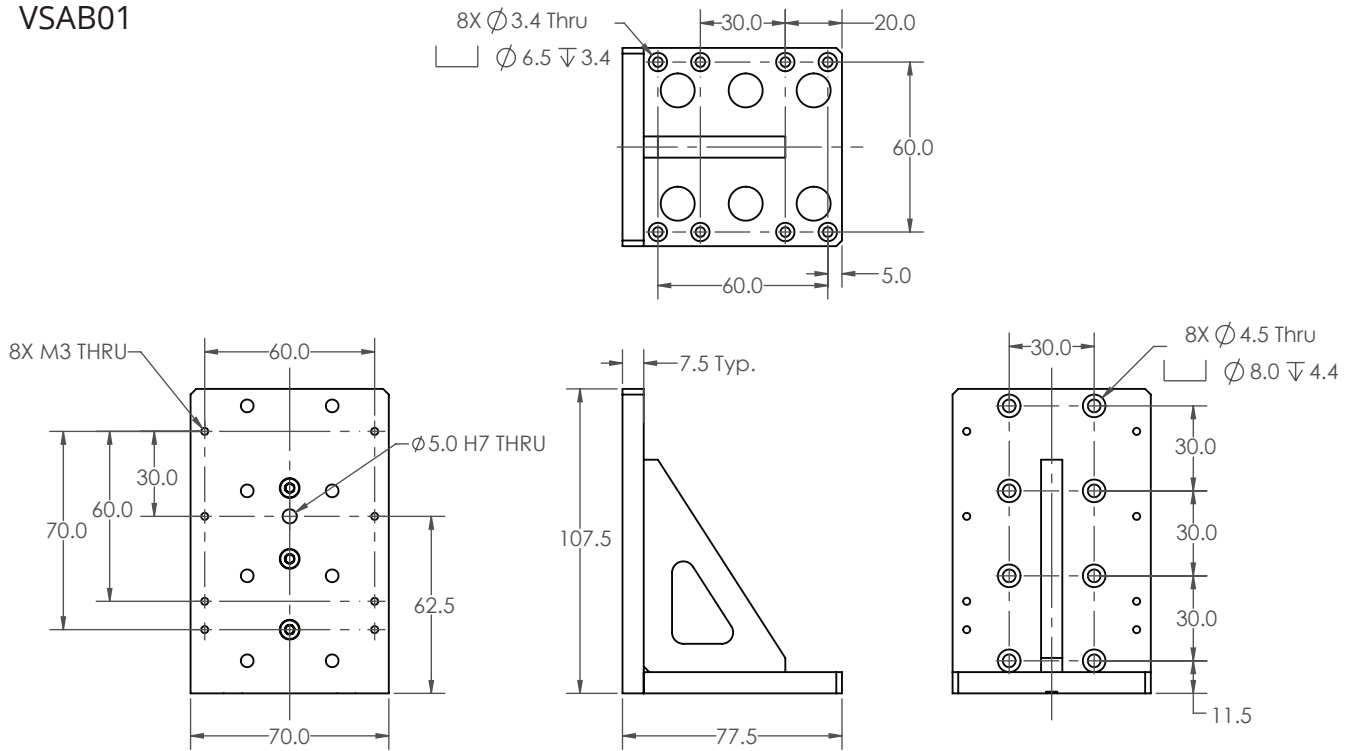

VSAB02

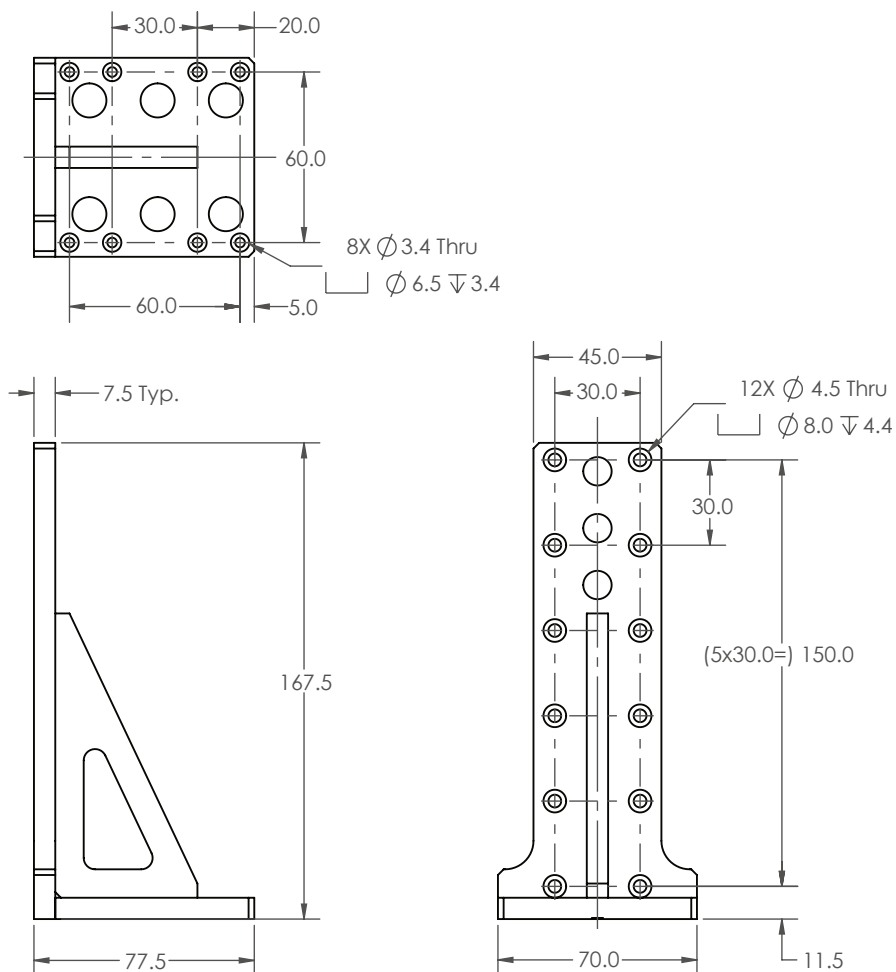

DIMENSIONS

VSAT01

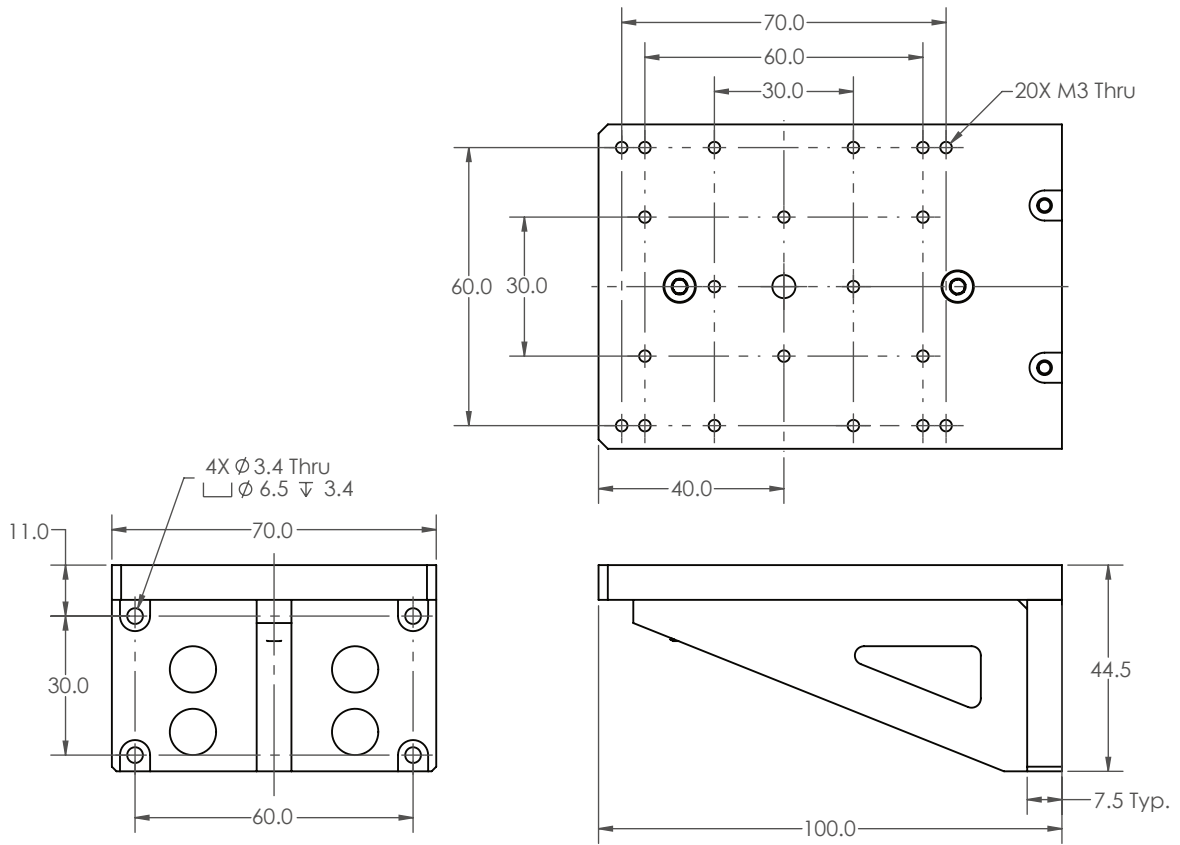

APPLICATION EXAMPLES

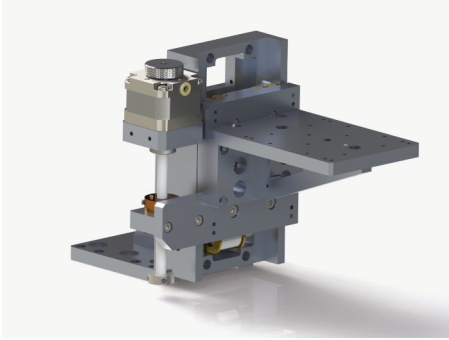

EXAMPLE 1

VSM17-X-050 with VSAB01 and VSAT01.

VSM17-X-050 is vertically oriented using the VSAB01. A mounting table is created using the VSAT01. This allows for convenient mounting of additional stages or samples.

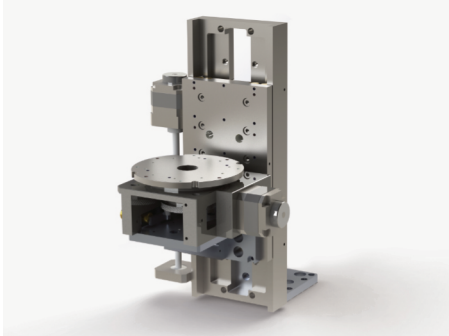

EXAMPLE 2

Z-R Mechanism with VSAB01 and VSAT01.

2-axis mechanism created with standard stages and mounting brackets. The VSM17-X-100 is oriented to the Z-axis using the VSAB01. A mounting table for the VSM17-R-72K is created using the VSAT01.

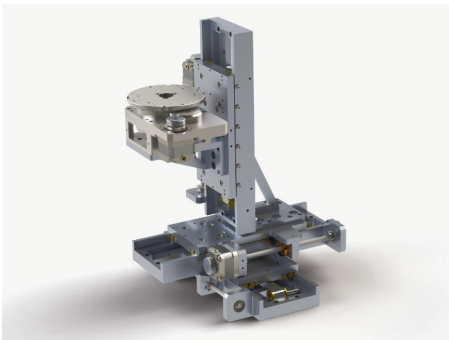

EXAMPLE 3

4-axis X-Y-Z-R Mechanism with VSAB02 and VSAT01.

Two VSM17-X-100s used for the X and Y-axis. The VSAB02 is used to reorient the VSM17-100 to the Z-axis. The VSAT01 is mounted to the carriage to create an additional mounting platform for the VSM17-R-3K6.

ORDERING INFORMATION

Options

SS Stainless steel construction

Order Code	
VSAB01	90° Mounting Bracket (Small)
VSAB02	90° Mounting Bracket (Large)
VSAT01	90° Table

Related Products	
VSM17-X-xxx	Linear stage (rigid) (xxx = travel in mm)
VSM17-R-xxx	Rotation stage (xxx = steps per rotation)
VSM17-Z-xxx	Linear vertical stage (xxx = travel in mm)
VSM17-G-xxx	Goniometer stage (xxx = rotational centre in mm)
VSM23-X-xxx	Linear stage (xxx = travel in mm)



Arun Microelectronics Ltd.
Unit 2, Bury Mill Farm
Bury Gate
PULBOROUGH
RH20 1NN
United Kingdom

Tel: +44 (0)1903 884141
Email: sales@arunmicro.com

AML pursues a policy of continuous improvement and reserves the right to make detail changes to specifications without consultation. E and OE.