

# Ultra High Vacuum Stepper Motors

1.8°, two phase hybrid stepper motors

AML stepper motors are specifically designed for use in UHV environments making them ideally suited for low speed precision in-vacuum manipulation without the use of particle generating motion feed-throughs. The considerable reduction in mechanical complexity, absence of metal to metal sliding surfaces and low outgassing characteristics make these motors especially suitable for sensitive handling applications



## FEATURES

The model D motors are two phase hybrid stepper motors, available in a range of standard sizes and torque ratings. Standard motors provide 200 full steps per revolution, are suitable for use below  $1 \times 10^{-10}$  mbar and temperatures between  $-65^{\circ}\text{C}$  to  $+175^{\circ}\text{C}$ . Extended low temperature range ( $-196^{\circ}\text{C}$ ) versions, radiation hard versions ( $1 \times 10^6$  Gy), shaft modifications and hybrid bearings are all available options.

All motors are designed, cleaned, hand assembled and conditioned to UHV standards in an ISO Class 7 cleanroom.

Model	Holding Torque mNm	Detent Torque mNm	Rotor Inertia gcm <sup>2</sup>	Max.Axial Force N	Max. Radial Force <sup>(1)</sup> N	Mass g	Current Per Phase A	Phase Resistance at 20°C Ω	Phase Inductance mH
D35.1	70	8	10	9	15	190	1.0	4.7	3.8
D42.1	180	8	35	9	15	350	1.0	5.3	6.6
D42.2	360	14	68	9	15	470	1.0	6.8	10.5
D42.3	450	20	102	9	15	610	1.0	8.5	19.5
D57.1	800	30	300	13	40	700	1.0	10.5	27.0
Vacuum environment		<math>1 \times 10^{-10}</math> mbar							
Operating temperature		-65°C to +175°C							
Temperature sensor		Type 'K' thermocouple standard or PT100 optional							
Bakeout temperature		200°C							
Step angle		1.8°							
Step angle tolerance		±5%							
Lead length		1.5m							

(1) 20mm from the flange

## SPEED VS TORQUE CHARACTERISTICS

The performance shown on these graphs was obtained using an SMD210 drive operating with standard settings for step division.

SMD210 is a switch-mode, bipolar, current-regulating drive with a nominal source of 67volts, optimised for use with vacuum motors. At low speed where step division is active the RSS (root sum of squares) of phase current is set to the nominal current. Over most of the speed range the drive operates in wave mode with nominal set current in only one energised phase.

Different drives will produce different speed / torque curves. Drives capable of producing a total phase current of more than 1A RSS may damage the insulation. Drives with significantly lower source voltages may result in poor high speed performance. Use of the embedded thermocouple is essential for motor protection.

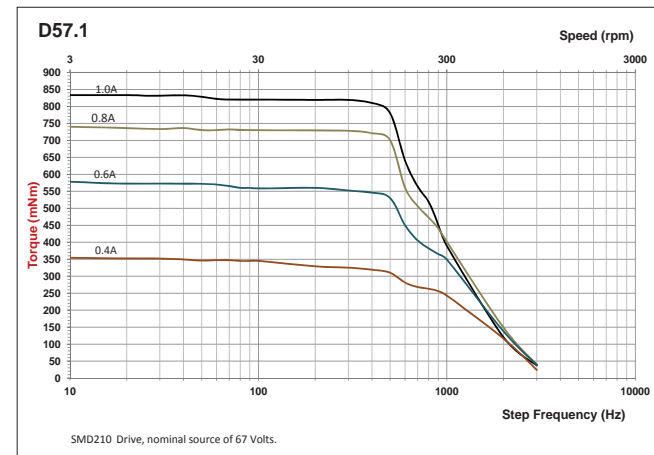
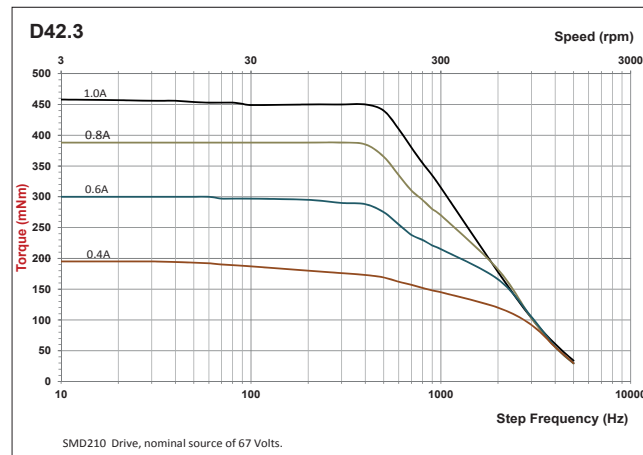
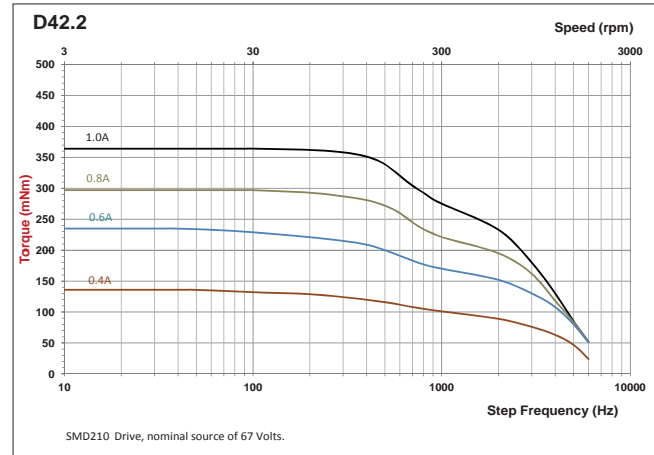
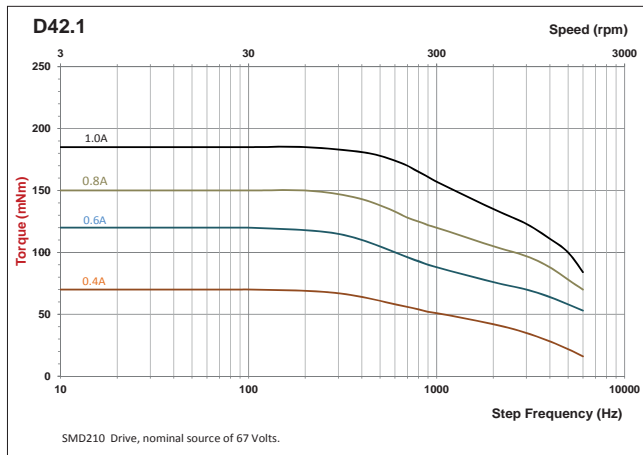
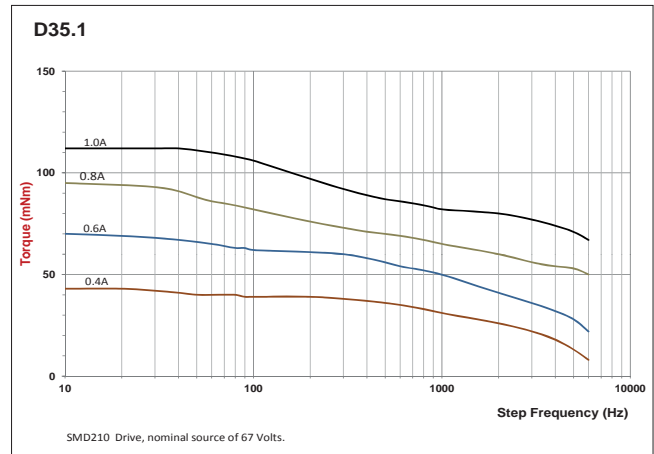

**DIMENSIONS**

**D35.1**

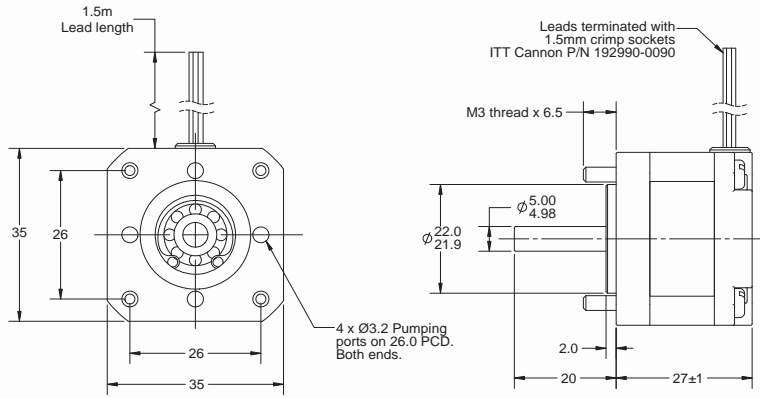

**D42.X**

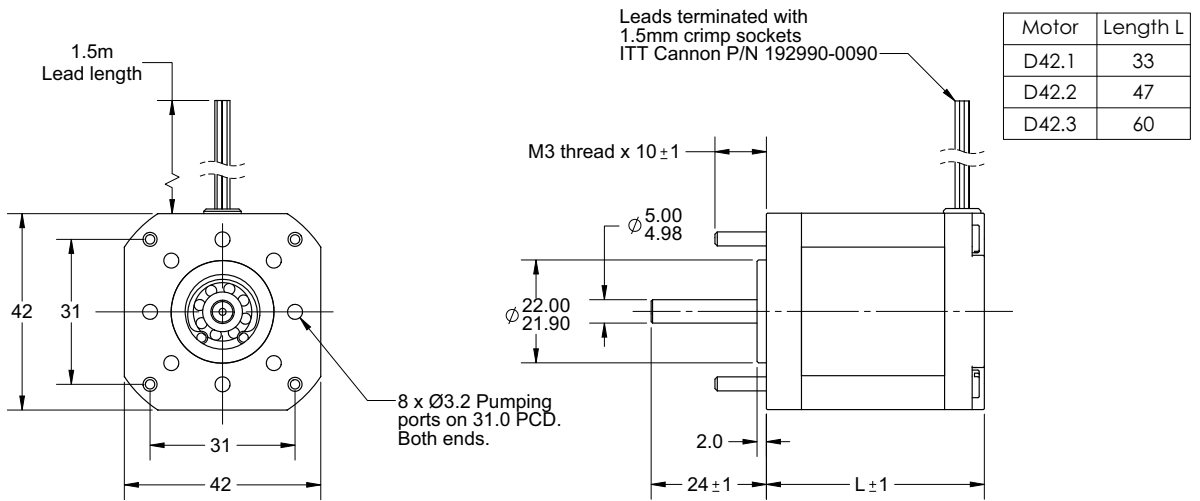

**D57.1**

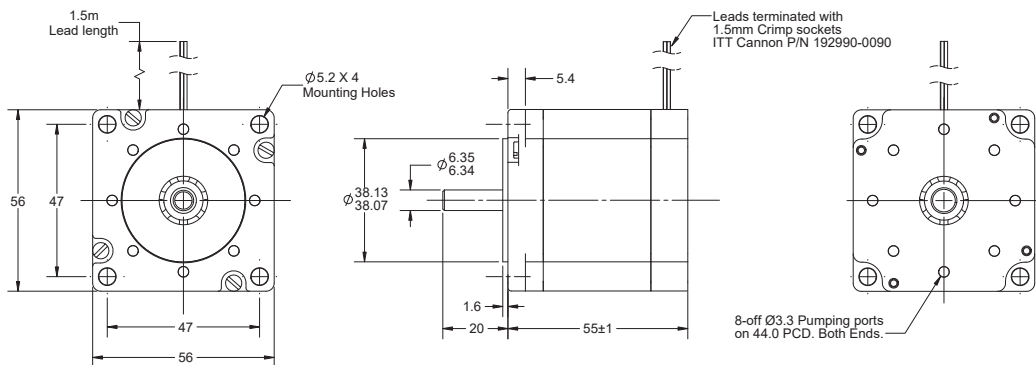

## ELECTRICAL CONNECTION

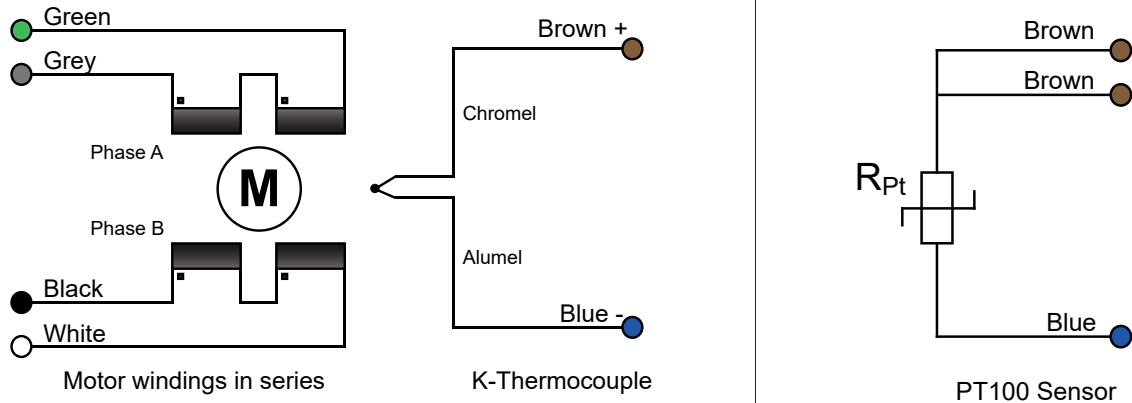

## ORDERING INFORMATION

### Bearings

Standard motors are fitted with open stainless steel bearings lubricated with NyeTorr® 6300 ultra low outgassing UHV grease.

For low duty applications where UHV grease is not permitted specify option 'H' hybrid bearings. These have silicon nitride ceramic balls, dry lubricated with Tungsten disulfide.

### Options

- H** Hybrid ceramic bearings
- R** Gamma radiation hardened to  $1 \times 10^6$  Gy
- X** Shaft modification. Please provide a sketch of your requirement
- C** Cryogenic. Extended operating temperature range.  $-196^{\circ}\text{C}$  to  $+175^{\circ}\text{C}$
- P** PT100 temperature sensor in lieu of thermocouple.

Order Code	
D35.1	70mNm UHV Stepper Motor
D42.1	180mNm UHV Stepper Motor
D42.2	360mNm UHV Stepper Motor
D42.3	480mNm UHV Stepper Motor
D57.1	800mNm UHV Stepper Motor
Related products	
SMD210	Stepper motor drive
MLF18F	18-way electrical feedthrough
MLF18NBL	3-metre lead, SMD210 to MLF18F

Order code format	
	D42.1 R
Order Code	
Option	



Arun Microelectronics Ltd  
Bury Mill Farm  
Bury Gate  
Bury  
PULBOROUGH  
RH20 1NN

Tel: +44 (0)1903 884141  
email: sales@arunmicro.com

AML pursues a policy of continuous improvement and reserves the right to make detail changes to specifications without consultation. E and OE.