

SG35 Inline Spur Gearhead

UHV Inline Spur Gearhead for D35.1 Stepper Motors

The SG35 series of gearheads are designed specifically for AML's D35.1 UHV stepper motors. Primarily used for increasing resolution, torque multiplication and inertia matching. They are designed for maximum torque capacity, high efficiency and zero backlash.

D35.1 UHV stepper motor included.

FEATURES

- Suitable for use below 1×10^{-10} mbar
- 5:1 ratio
- Efficiency: >75%
- Low inertia
- High precision, zero backlash
- Bakeable to 200 °C
- Operational temperature range -65 °C to +190 °C
- In-line shafts
- Anti-backlash spur gears
- RoHS compliant

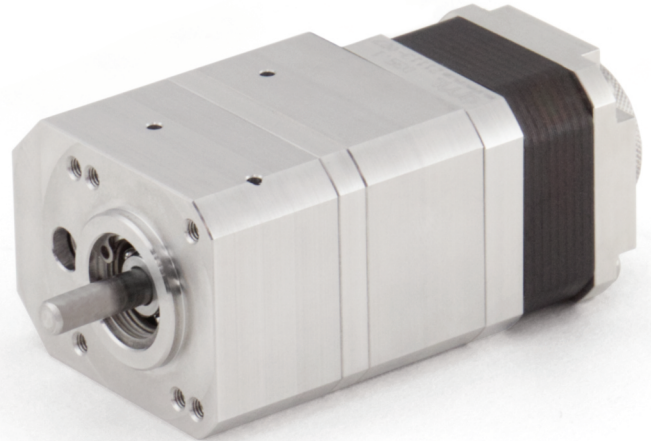

SPECIFICATION

Reduction Ratio	Nominal Output Torque ⁽¹⁾	Maximum Acceleration Torque	Gear Inertia	Efficiency at nominal torque	Radial Load ⁽²⁾	Axial Load ⁽²⁾	Mass	Lubrication
(:1)	mNm	mNm	kg-cm ²	%	N	N	kg	
5	350	450	0.25	75	160	100	0.58	Nyetorr® 6300

Direction of rotation: Same as input
 Vacuum environment: $<1 \times 10^{-10}$
 Max. temperature: +200 °C
 (1) Measured at 500 Hz
 (2) @75 rpm, radial load applied at centre of shaft

DIMENSIONS

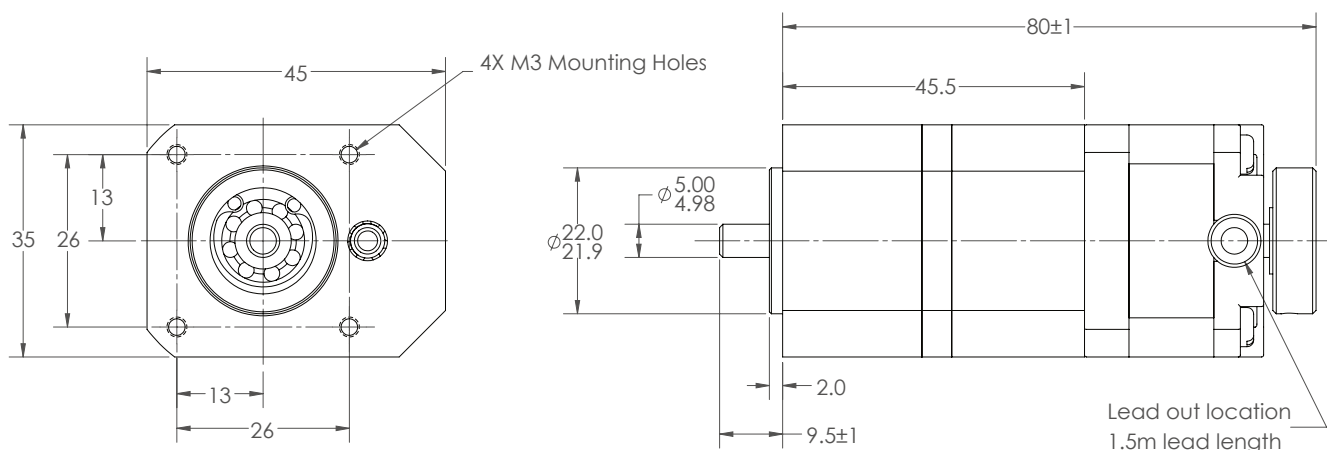

ORDERING INFORMATION

Order Code	
SG35-005	UHV Spur Inline Gearhead for D35.1 Stepper Motor (Ratio 5:1)

Related Products	
D35.1	75 mNm UHV stepper motor



Arun Microelectronics Ltd.
Unit 2, Bury Mill Farm
Bury Gate
PULBOROUGH
RH20 1NN
United Kingdom

Tel: +44 (0)1903 884141
Email: sales@arunmicro.com

AML pursues a policy of continuous improvement and reserves the right to make detail changes to specifications without consultation. E and OE.