

RSX Rotation Stage

UHV Rotation Stage

AML ultra high vacuum compatible rotation stages are manufactured with UHV compatible material and construction methods in an ISO 7 cleanroom and utilise AML D35.1 UHV stepper motors.

The RSX3K6 features a precision cross-roller ring bearing providing high rotational accuracy capable of bearing loads in every direction. It has a 18mm clear aperture, anti-backlash spur gearing and can optionally be fitted with an optical UHV compatible rotary encoder.



SPECIFICATIONS

Rotation range	360°
Resolution in full steps	0.1°
Steps per revolution	3,600
Maximum loaded speed	100 rpm
Maximum torque	1 N·m
Centred load capacity (Normal)	100 kg
Backlash (Unloaded)	Less than resolution
Wobble	±4.0 µrad
Eccentricity	10.0 µm
Wobble compliance	10 µrad/N·m
Vacuum	1 x 10 ⁻¹⁰ mBar
Maximum temperature	200 °C (reduces to 120 °C when an optical encoder is fitted)
Aperture diameter	18 mm
Motor	D35.1
Mass including motor	1.7 kg

As standard RSX rotational stages are supplied lubricated with Nyetorr® 6300 low-vapour pressure (6×10^{-12} mbar) grease. Dry lubrication with molybdenum disulfide is available as an alternative option but this will reduce the expected life.

DIMENSIONS

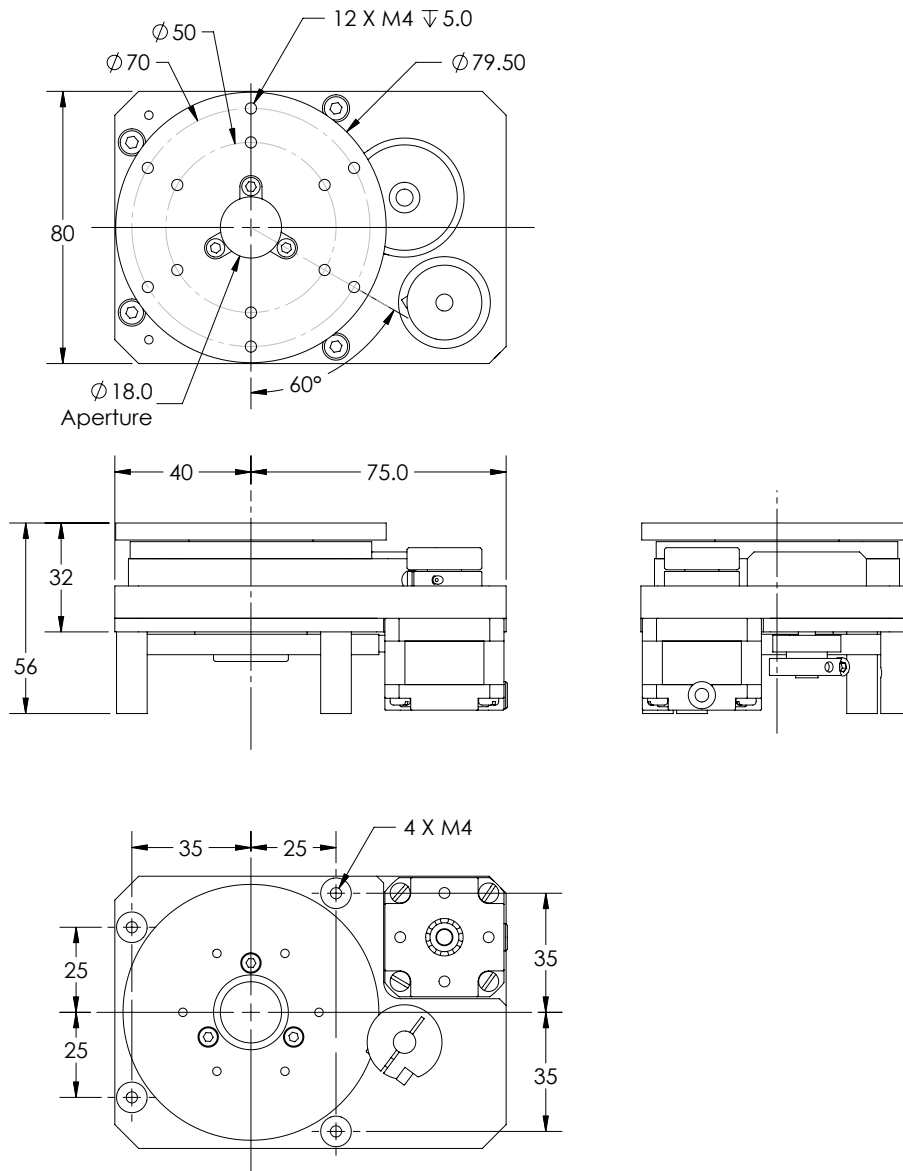

ORDERING INFORMATION

Order Code	
RSX3K6	Rotation stage 0.1° / step resolution
RSX3K6-E	RSX3K6 with optical encoder

Related Products	
SMD210	Stepper Motor Drive
MLF18F	18-way Electrical Feedthrough
MLF18NBL	3 metre lead, SMD210 to MLF18F
LTVL-xxx	Translation Stage, 5 μ m (xxx = travel in mm)



Arun Microelectronics Ltd.
 Unit 2, Bury Mill Farm
 Bury Gate
 PULBOROUGH
 RH20 1NN
 United Kingdom

Tel: +44 (0)1903 884141
 Email: sales@arunmicro.com

AML pursues a policy of continuous improvement and reserves the right to make detail changes to specifications without consultation. E and OE.