



ARUN MICROELECTRONICS LTD

APPLICATION NOTE No 27, Issue 3 , 2015

Axial and Radial loads on AML stepper motor bearings.

AML stepper motors are fitted with two bearings, which support the rotor at each end of the housing. They are extremely reliable in clean vacuum situations and have useful service lives of decades with low imposed loading. The two principal causes of failure are both due to misuse: break-up of the ball cage due to ingress of contaminants or damage due to extreme shock loads such as are caused by dropping the motor on its shaft end.

Axial and radial loads imposed on the motor should be avoided where possible by the design of the mechanism to which the motor is applied. Loads comparable to the bearing ratings will shorten their lives in unpredictable ways. It will usually be more convenient to replace bearings in a mechanism than in a motor, which has to be de-magnetised, cleaned, re-magnetised and baked during any service.

Axial loads.

The bearing at the opposite end to the principal mounting face of the motor is preloaded against the motor end cap by a spring. The free travel of the spring is about 0.3mm and is fully exercised by a force of 2½kg against the shaft end. It is important to design linear mechanisms so that this free travel is not added to the backlash in the mechanism. This can be achieved by preload springs, gravity or by decoupling the motor from the load by gearing.

Linear mechanisms with leadscrews can exert considerable axial forces if they are stalled against rigid end stops. All AML mechanisms are designed with vernier stops, which stall the motor directly, avoiding this potential problem. If there is any possibility of a linear mechanism crashing into rigid obstructions it may be necessary to use torque-limiting to reduce the resulting force. If a linear mechanism stalls due to excessive friction no additional axial load is imposed on the leadscrew.

For all AML motors direct axial loads of greater than 10kg are not recommended.

Radial loads.

Radial loads on motors arise in two main ways. The first is a simple cantilever extension on the shaft, where the forces on the bearings can be easily calculated by reference to drawing Q47-015, which is appended. Note that the radial forces on the bearings are magnified by the extension acting as a lever. The second arises in linear mechanisms where the leadscrew or other extension is directly coupled to the motor shaft and supported or constrained by a nut or bearing. Any misalignments will give rise to significant radial forces on the motor bearings.

For all AML motors direct radial loads of greater than 10kg are not recommended.

DRAWING NUMBER:
Q47-015

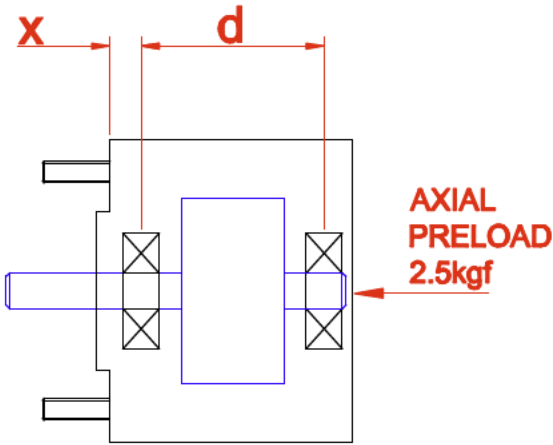

MOTOR	d mm	x mm
D28.1	22.0	7.0
D35.1	17.7	4.0
D42.1	23.6	5.0
D42.2	37.5	5.0
D42.3	49.5	5.0
D57.1	40.1	6.4

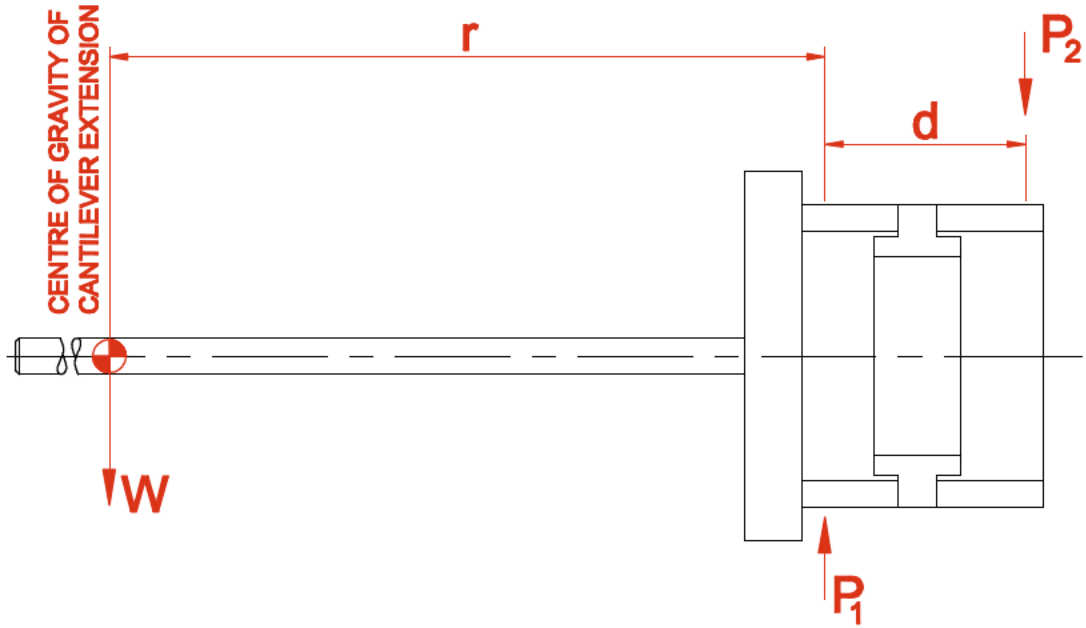

$$P_1 = (1 + \frac{r}{d}) W$$

$$P_1 \leq 10\text{kgf}$$

$$P_2 = \frac{r}{d} W$$

$$P_2 \leq 10\text{kgf}$$

NOTE:
1. REF. APPLICATION NOTE No.26.

© COPYRIGHT 2012 ARUN MICROELECTRONICS LTD.

CANTILEVER LOADS
ON MOTOR SHAFTS

GEN. TOL. LINEAR: ± 0.10
ANGULAR: $\pm 0.20^\circ$

STOCK NUMBER:
N/A

SCALE: N/A DIMENSIONS IN mm

A4 SHEET 01 OF 01

MATERIAL:
N/A

FINISH:
N/A

ISSUE:
B

DRAWING NUMBER:
Q47015

ISSUE	DRAWN	DATE	MODIFICATION
B	PJB	20/01/12	D Series Motors
B	RMF	09/07/02	RELEASE